

ITEM NO.	PART NUMBER	DESCRIPTION	DESCRIPTION 2	QTY
1	FB-096-22-2	BEAM, PULTRUDED STOCK	SERIES 22 x 96 in, GRAY	1
2	TG0688-0027	BUSHING	11/16 in x 4-1/4 in	4
3	TG0688-0028	BUSHING	11/16 in x 3-1/4 in	2
4	TG0813-0030	BUSHING	13/16 in x 3-1/4 in	2
5	FOAM	-	-	1
6	EC22-0004-2	END CAP	SERIES 22, GRAY	2
7	TM-0044	MOUNT ASSEMBLY, TANGENT	SD	1
8	PL-0037	PLATE, FRONT		1
9	HB0750-0001	HEX BOLT	3/4 in - 10 x 5-1/2 in	2
10	LW0750-0001	LOCK WASHER	3/4 in	2
11	HN0750-0001	HEX NUT	3/4 in - 10	2

PUPI[®]
www.pupicrossarms.com

REVISIONS			
REV.	DESCRIPTION	DATE	INITIALS
1.0	ADD REPLACES DRAWING NAME	2011-11-18	EFH
2.0	ADDED REPLACES PREVIOUS ITEM NOTE IN TITLE BLOCK	2011-11-29	EFH
3.0	CORRECTED REPLACES PREVIOUS ITEM: TB22-96-XB WAS TB22-96-X	2012-01-03	EFH
3.1	REDRAW IN SOLIDWORKS	2013-02-05	RAF

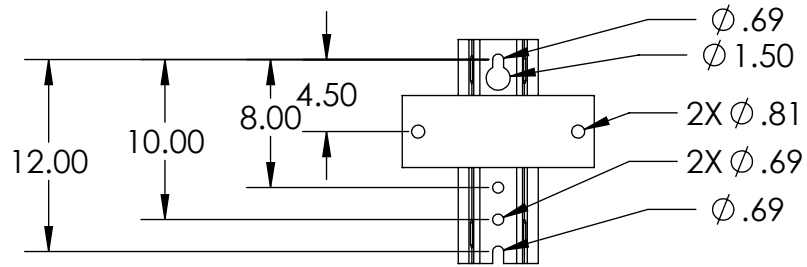

DETAIL -A-

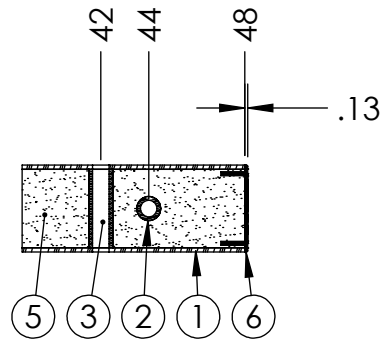

SECTION A-A
SCALE 1 : 8

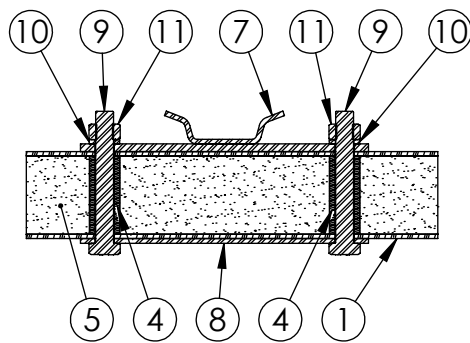

SECTION B-B
SCALE 1 : 8

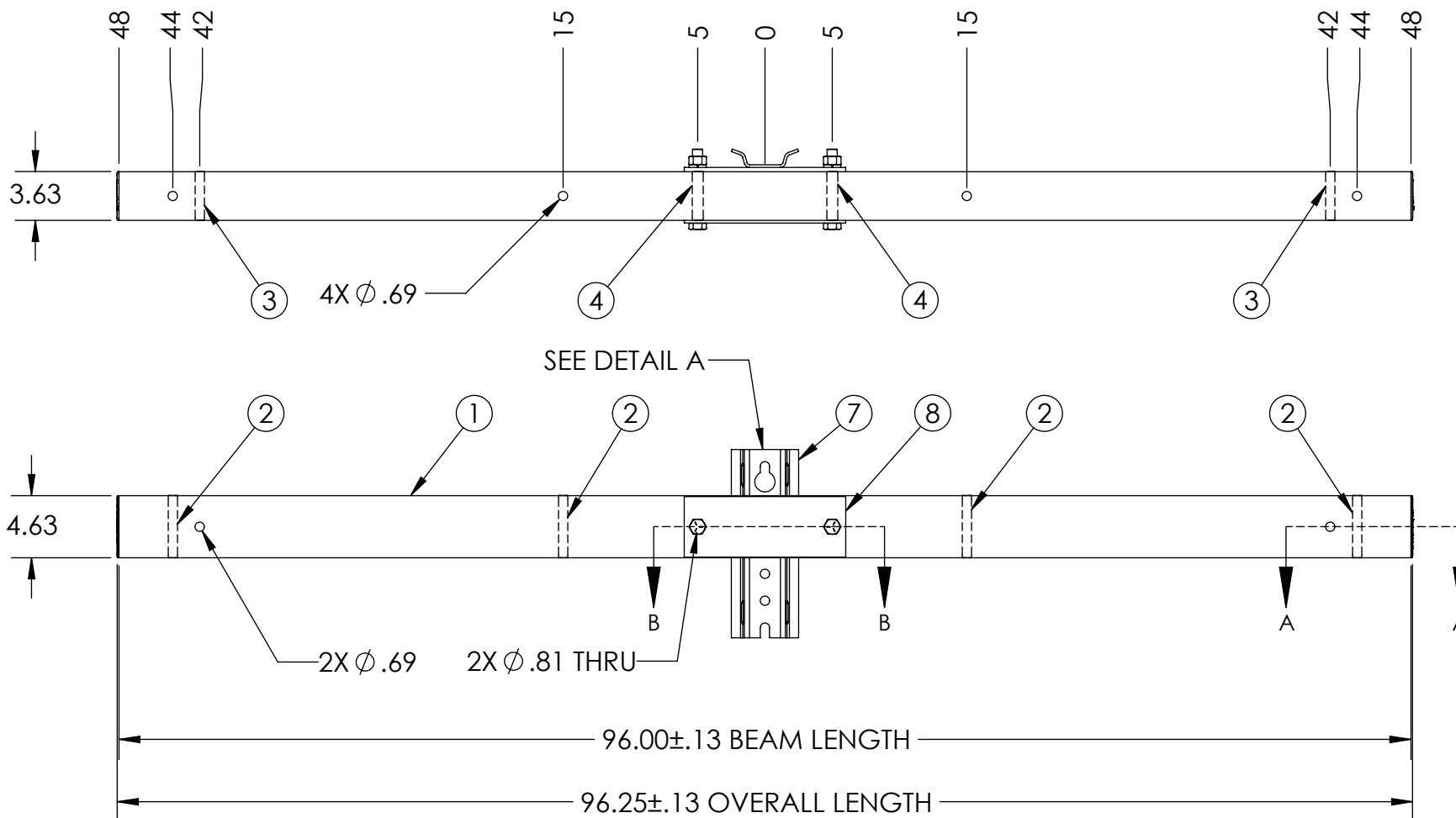

NOTES:
1. CENTER OF MOUNT HOLE(S) TO HOLES TOLERANCE ±0.06

<p>-----UNLESS OTHERWISE SPECIFIED----- DIMENSIONS ARE IN INCHES INTERPRET DIM AND TOL PER ASME Y14.5-2009 ANGULAR: MACH ±2° BEND ±2° TWO PLACE DECIMAL ±0.02 THREE PLACE DECIMAL ±0.005</p>	<p>STATE: RELEASED 2013-03-07 DRAWN: RAF 2013-02-05 CHECKED: BRH 2013-03-07 APPROVED: BRH 2013-03-07</p>	<p>GEOTEK <i>A Whole New World of Composites</i> 1421 SECOND AVE NW STEWARTVILLE, MN 55976 (800) 533-1680 www.geotekinc.com</p>
	<p>FINISH: REPLACES: TB22-96-XB</p>	
<p>PROPRIETARY AND CONFIDENTIAL THE INFORMATION CONTAINED IN THIS DRAWING IS THE SOLE PROPERTY OF GEOTEK. ANY REPRODUCTION IN PART OR AS A WHOLE WITHOUT THE WRITTEN PERMISSION OF GEOTEK IS PROHIBITED.</p>	<p>THIRD ANGLE PROJECTION</p>	<p>SIZE: DWG. NO. B TB220009603X2 SCALE: 1:12 WEIGHT: 34.03 LBS</p>
		<p>REV: 3.1 SHEET 1 OF 1</p>