

ITEM NO.	PART NUMBER	DESCRIPTION	DESCRIPTION 2	QTY
1	FB-057-1000-2	BEAM, PULTRUDED STOCK	SERIES 1000 x 57 in, GRAY	1
2	TG0563-0013	BUSHING	9/16 in x 3-11/16 in	3
3	TG0813-0018	BUSHING	13/16 in x 1-11/16 in	2
4	FOAM	-	-	1
5	EC10-0007-2	END CAP	SERIES 1000, GRAY	2
6	TM-0044	MOUNT ASSEMBLY, TANGENT	SD	1
7	PL-0003	PLATE, FRONT		1
8	HB0750-0005	HEX BOLT	3/4 in - 10 x 4 in	2
9	LW0750-0001	LOCK WASHER	3/4 in	2
10	HN0750-0001	HEX NUT	3/4 in - 10	2
11	BK-0118	ANGLE BRACKET		2
12	BK-0124	T-BRACKET		1
13	HB0500-0029	HEX BOLT	1/2 in - 13 x 5-1/2 in	3
14	CB0500-0008	CARRIAGE BOLT	1/2 in - 13 x 1-1/2 in	6
15	SW0563-0009	SQUARE WASHER	9/16 in, 2 in x 1/4 in	3
16	TW0500-0008	TOOTH LOCK WASHER	1/2 in	6
17	LW0500-0007	LOCK WASHER	1/2 in	9
18	HN0500-0005	HEX NUT	1/2 in - 13	9

**PUPI**<sup>®</sup>  
www.pupicrossarms.com

REVISIONS			
REV.	DESCRIPTION	DATE	INITIALS

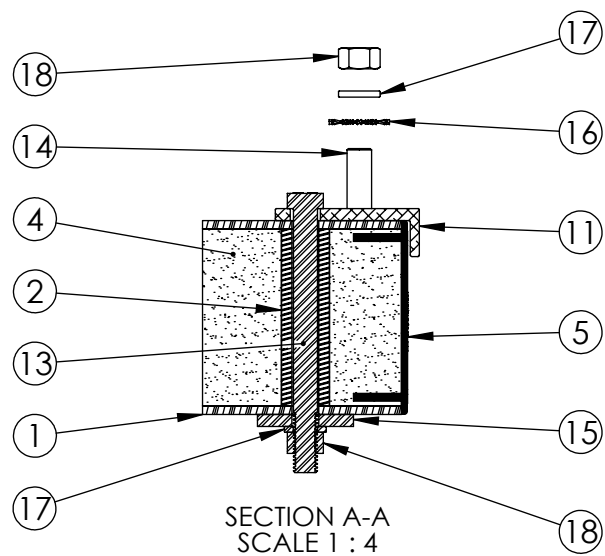
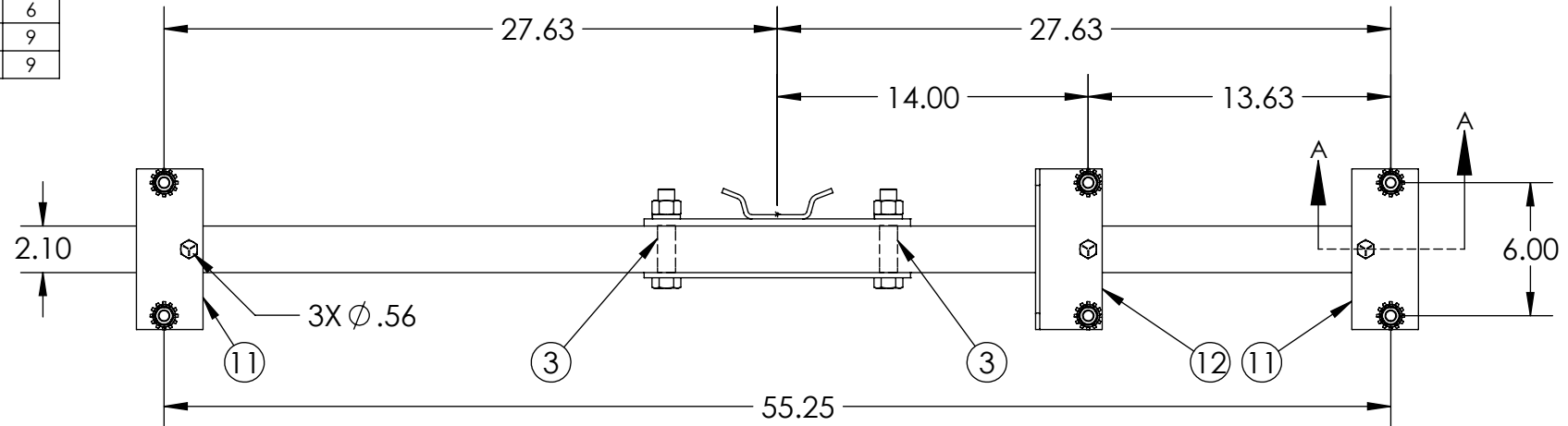
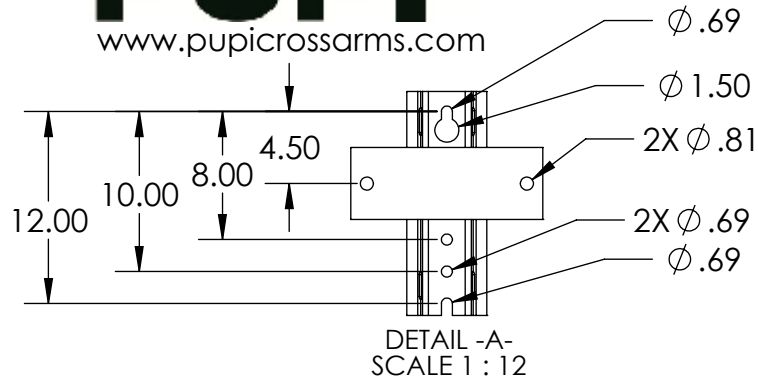

SEE DETAIL -A-

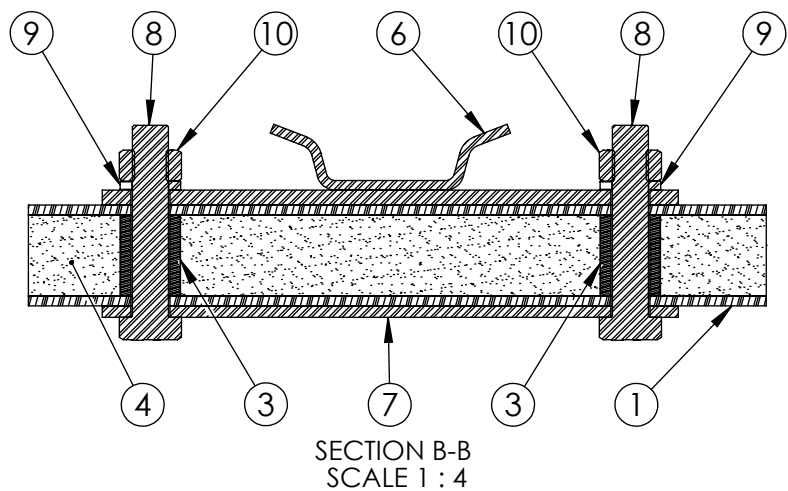
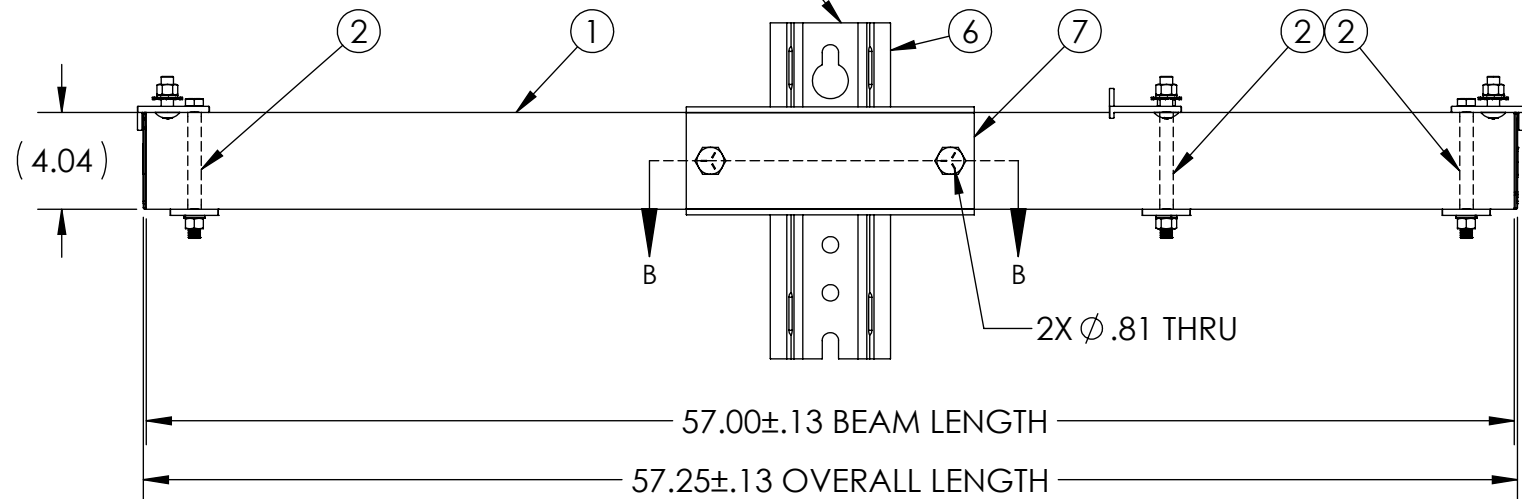

NOTES:  
1. CENTER OF MOUNT HOLE(S) TO HOLES TOLERANCE ±0.06

-----UNLESS OTHERWISE SPECIFIED-----  
DIMENSIONS ARE IN INCHES  
INTERPRET DIM AND TOL PER ASME Y14.5-2009  
ANGULAR: MACH ±2°  
BEND ±2°  
TWO PLACE DECIMAL ±0.02  
THREE PLACE DECIMAL ±0.005

**PROPRIETARY AND CONFIDENTIAL**  
THE INFORMATION CONTAINED IN THIS DRAWING IS THE SOLE PROPERTY OF GEOTEK. ANY REPRODUCTION IN PART OR AS A WHOLE WITHOUT THE WRITTEN PERMISSION OF GEOTEK IS PROHIBITED.

STATE:	APPROVED	2014-08-21
DRAWN:	RAF	2014-08-07
CHECKED:	LPB	2014-08-21
APPROVED:	LPB	2014-08-21
MATERIAL:		

FINISH:  
REPLACES:

THIRD ANGLE PROJECTION

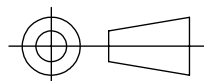

**GEOTEK**  
A Whole New World of Composites  
1421 SECOND AVE NW  
STEWARTVILLE, MN 55976  
(800) 533-1680  
www.geotekinc.com

DESCRIPTION:  
**EQUIPMENT ARM ASSEMBLY**  
**SERIES 1000, 57 in**

SIZE:	DWG. NO.	REV:
<b>B</b>	<b>EB10000570012</b>	<b>0.0</b>
SCALE: 1:8	WEIGHT: 28.12 LBS	SHEET 1 OF 1