

ITEM NO.	PART NUMBER	DESCRIPTION	DESCRIPTION 2	QTY
1	FB-096-2500-2	BEAM, PULTRUDED STOCK	SERIES 2500 x 96 in, GRAY	1
2	TG0688-0004	BUSHING	11/16 in x 3-1/8 in	4
3	TG0813-0006	BUSHING	13/16 in x 3-1/8 in	2
4	TG0688-0003	BUSHING	11/16 in x 4-1/16 in	2
5	FOAM			1
6	EC25-0003-2	END CAP	SERIES 2500, GRAY	2
7	DM-0046	MOUNT ASSEMBLY, DEADEND	HD	1
8	HB0750-0001	HEX BOLT	3/4 in - 10 x 5-1/2 in	2
9	LW0750-0001	LOCK WASHER	3/4 in	2
10	HN0750-0001	HEX NUT	3/4 in - 10	2
11	SW0688-0002	SQUARE WASHER	11/16 in, 3-1/2 in x 1/4 in	4
12	LW0625-0004	LOCK WASHER	5/8 in	2
13	EN0625-0003	EYE NUT	5/8 in - 11	4
14	TRO625-0001	THREADED ROD	5/8 in - 11 x 7-1/2 in	2

**PUPI**<sup>®</sup>  
www.pupicrossarms.com

REVISIONS			
REV.	DESCRIPTION	DATE	INITIALS
1.0	ADDED REPLACES PREVIOUS ITEM IN TITLE BLOCK	2011-11-02	CAS
2.0	ADDED REPLACES PREVIOUS ITEM NOTE IN TITLE BLOCK	2011-11-29	EFH
2.1	REDRAWN IN SOLIDWORKS	2013-01-24	RAF

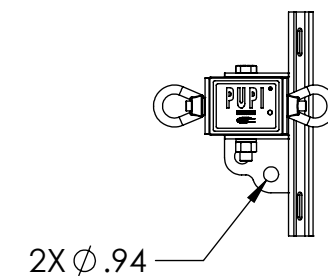
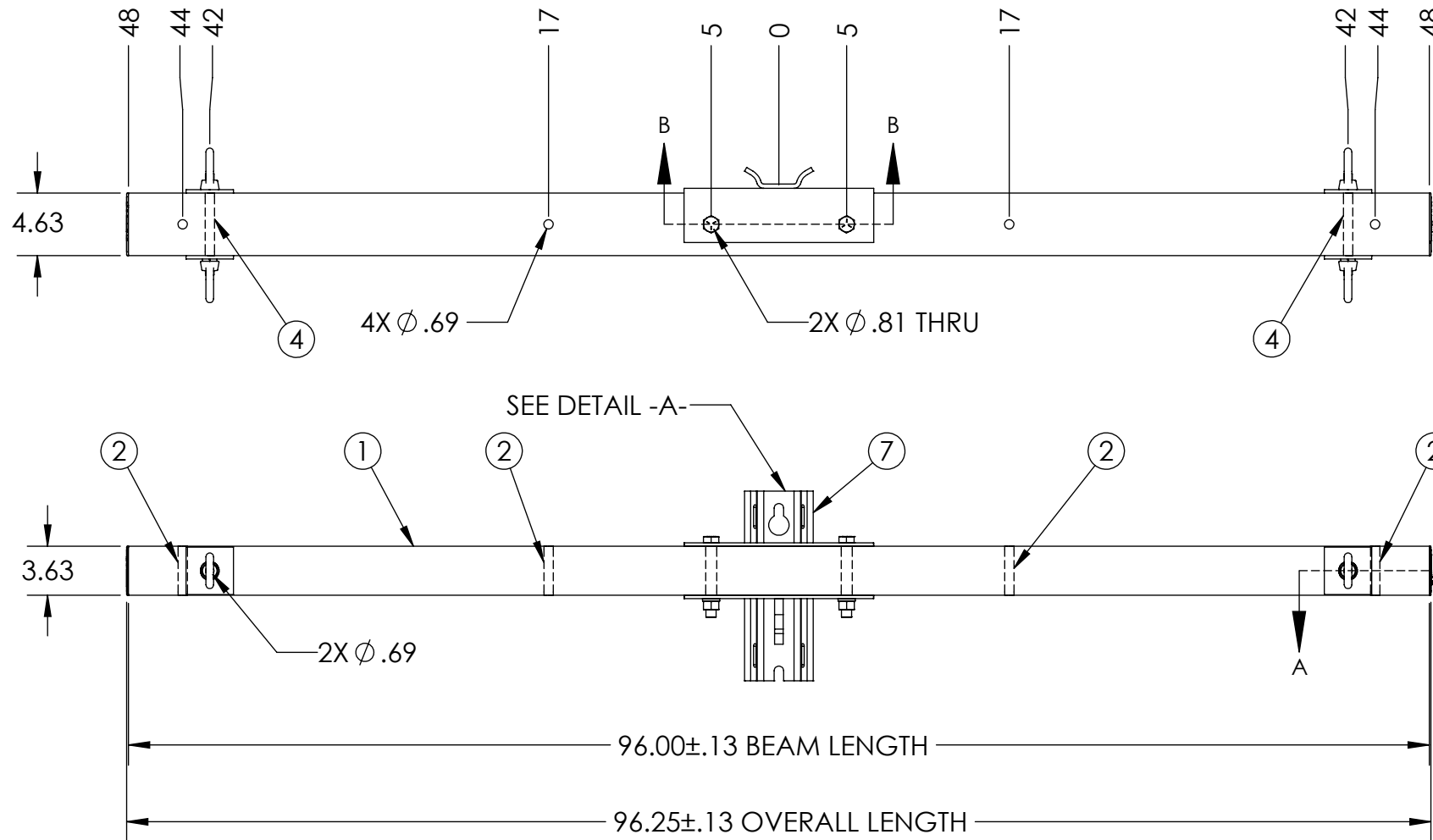
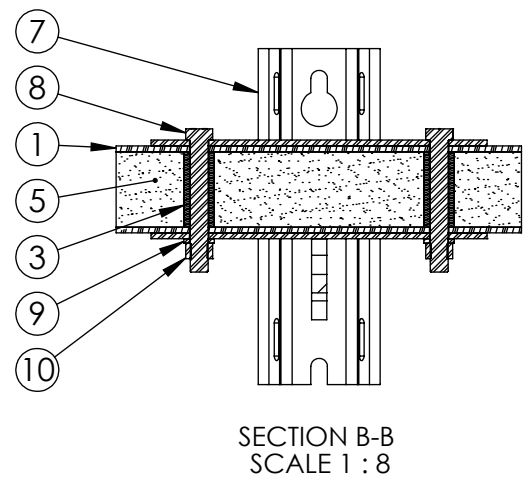
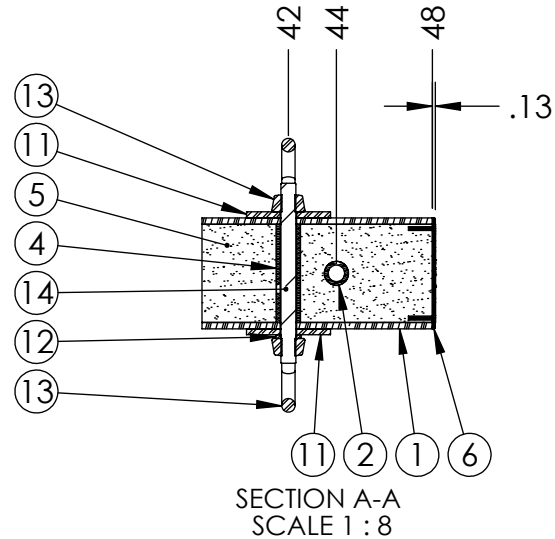
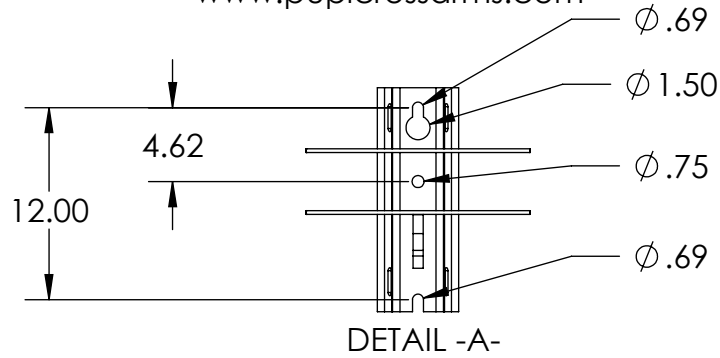

NOTES:  
1. CENTER OF MOUNT HOLE(S) TO HOLES TOLERANCE ±0.06

-----UNLESS OTHERWISE SPECIFIED-----  
DIMENSIONS ARE IN INCHES  
INTERPRET DIM AND TOL PER ASME Y14.5-2009  
ANGULAR: MACH ±2°  
BEND ±2°  
TWO PLACE DECIMAL ±0.02  
THREE PLACE DECIMAL ±0.005

**PROPRIETARY AND CONFIDENTIAL**  
THE INFORMATION CONTAINED IN THIS DRAWING IS  
THE SOLE PROPERTY OF GEOTEK. ANY REPRODUCTION  
IN PART OR AS A WHOLE WITHOUT THE WRITTEN  
PERMISSION OF GEOTEK IS PROHIBITED.

STATE: RELEASED 2013-03-14  
DRAWN: RAF 2013-01-24  
CHECKED: TSK 2013-03-14  
APPROVED: TSK 2013-03-14

MATERIAL:  
FINISH:  
REPLACES:  
DA2500-96E2-B7X

THIRD ANGLE PROJECTION

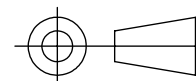

**GEOTEK**  
A Whole New World of Composites  
1421 SECOND AVE NW  
STEWARTVILLE, MN 55976  
(800) 533-1680  
www.geotekinc.com

DESCRIPTION:  
**DEADEND ASSEMBLY, SERIES 2500**  
**96 in, PUPI B7X**

SIZE: DWG. NO. **B DA2500096E2B7X2** REV: **2.1**  
SCALE: 1:12 WEIGHT: 52.8 LBS SHEET 1 OF 1